

Fancy box

Chris Tribe shows us how he achieved this simple yet stylised box for an elegant wall cabinet

The intention in the design of this piece was to make a simple box which would lend itself to batch production. In order to keep the costs down, ornamentation was kept to a minimum, emphasis being placed on elegant lines and decorative veneers. For some time I have also been interested in the idea of making a piece without the use of metal fittings.

As I was making the box, I realised that by increasing the size and adjusting the proportions, the design could be adapted to make a wall cabinet. I then thought that a small table to stand below the cabinet may be a good idea. So this project rather got out of hand!

In this article I will describe the making of the box and in subsequent articles, the cabinet and table will be covered.

TIMBER

The box consists of a dovetailed base in American walnut (*Juglans nigra*) with a laminated curved lid, in maple (*Acer saccharum*) fitted into a turned rod at the back. The lid pivots on spigots that engage in holes in the sides of the base. It is fitted internally to take writing materials. I have also made it in cherry (*Prunus spp*) and birds eye maple (*Acer campestre*), which is an attractive combination.



THE FORMER

Start by making accurate drawings of the proposed piece – this can then be used as a reference for taking measurements and angles.

I decided that as this project would be suited to batch production, I would make a former big enough to make three lids at a time, which would also be big enough to make the cabinet door.

The former consists of bendy ply fitted over curved supports screwed to a base board at approximate 75mm (3in) intervals – this is topped off with a sheet of 1.5mm ($\frac{1}{16}$ in) birch ply to provide a smooth surface.

Make up the 18mm ($\frac{3}{4}$ in) MDF blanks for the supports – it is important that the edges are flat and square as any inaccuracy here will be reflected in the final shape of the former. Shape the first curved support using a router and trammel. The radius should be the required internal radius of the lid, less the thickness of the ply being used in the former. My lid had an internal radius of 385mm ($15\frac{3}{16}$ in).

TEMPLATES

Having made the first support using the trammel, use it as a template to shape the rest of the supports on the router table with a bearing guided panel trim. Firstly cut the curve roughly to shape on the bandsaw, then locate the template piece precisely using brass dowels located in holes in both pieces. When using the bearing guided cutter, ensure that the workpiece is supported as it is offered up to the cutter. Most tables have a small post to screw into the top for this purpose, otherwise clamp a support to the table.

STABILITY

To increase stability and aid location of the cross members, they are fitted into notches in the rails that run up either side. Prepare a piece the same width as the ends of the supports and twice the required thickness. Cut the notches using repeated passes on the radial arm saw. By marking out the notch interval less the width of the saw kerf on the saw fence and lining up the previously cut >

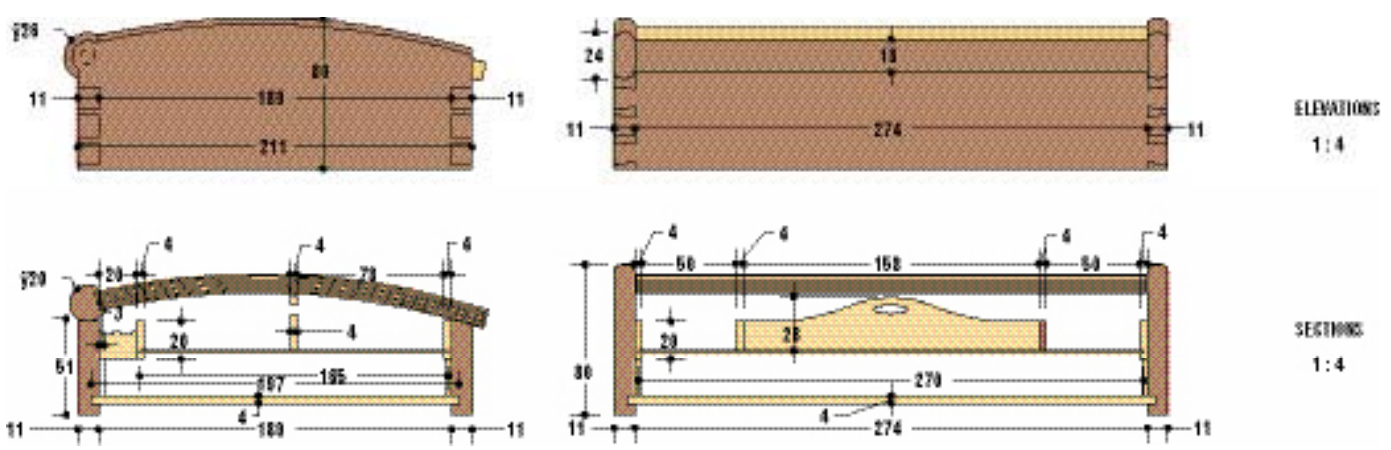
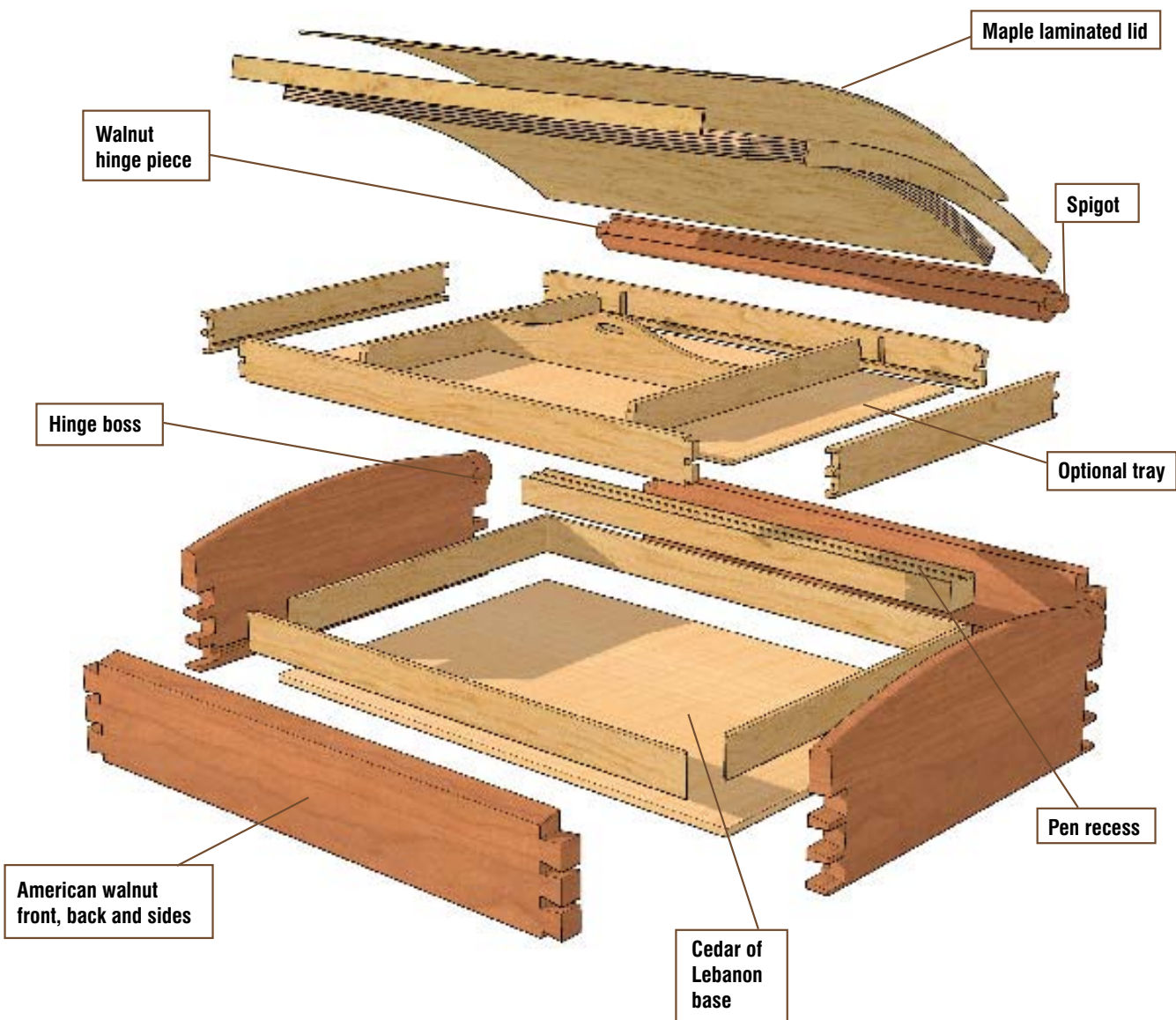

DRAWINGS BY SIMON RODWAY

PHOTOGRAPHS BY CHRIS TRIBE

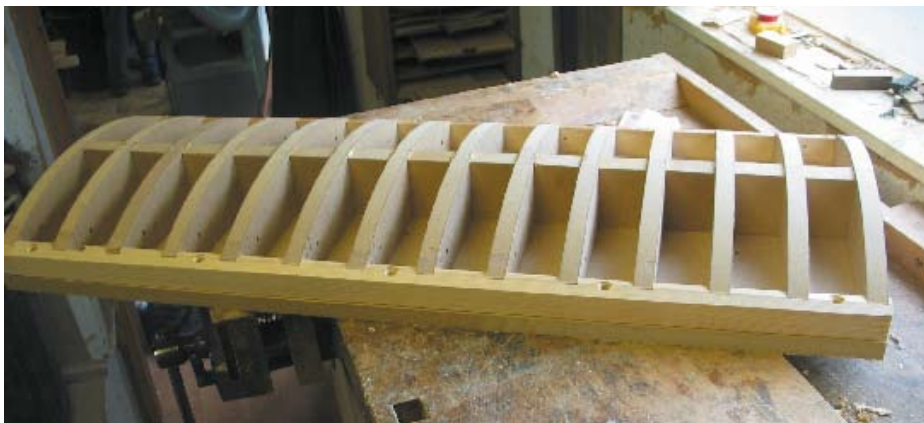

The former is large enough to make three lids at a time



Former with outer layers fitted. Note centre line



Lid laminations before trimming

< notch, it is possible to accurately cut the notches at regular intervals without having to mark out each one individually. Now cut the piece in half down the middle to give two identical cross pieces the required thickness.

Assemble the supports and cross pieces on the base board by screwing from underneath, and fit spacers down the middle for additional rigidity. Plane the tops of the cross rails flush with the supports.

Fit the ply layers by gluing them to the supports using the vacuum bag. I had a layer of 5mm ($\frac{3}{16}$ in) bendy ply and 1.5mm ($\frac{1}{16}$ in) birch ply. On completion, mark a line down the centre of the former to aid location when placing pieces on the former.

Some may say this is overkill and I could have got away with less supports or ply layers, however, experience has shown that scrimping at this stage can lead to unwanted undulating curves where the vacuum has distorted the former.

LAMINATING

Prepare the five layers of 1.5mm veneer and the decorative top and bottom veneers – the 1.5mm should be consecutive leaves to ensure grain match. Sometimes areas of the 1.5mm veneer can have an uneven texture from when it was originally cut, which

may lead to variation of thickness in the finished lamination, so clean it up with a cabinet scraper and coarse sandpaper. It is important to remember that even slight variations in thickness of veneer or glue line can become significant when multiplied by the number of laminations.

The subject of adhesives is a bit tricky – I tend to switch between cascamate and PVA, depending on whim. I have used a cross linking PVA which is supposed to avoid the problem of creep, however I occasionally have difficulties with joints opening or the veneer lifting when it is moistened to remove veneer tape. These problems do not arise with cascamate (also sold as extramite), however, on a warm day you have to work quickly before it thickens as it can produce an over-thick glue line. Additionally, cascamate as an urea formaldehyde glue is considered bad for the environment and also yourself probably – currently I am living with my environmental guilt and using cascamate (see John Lloyd's article on adhesives on page 12 of this issue).

Mark a line down the centre of the top veneer – this will be aligned on the centre line on the former when the assembly is in the vacuum bag.

Use a foam paint roller to spread the glue on the laminates on only one side each. Do not spread adhesive on the top and bottom veneers as they will curl up before you can get them in the bag, but apply it to the top and bottom laminates instead. Lay the assembly on the former in the vacuum bag, seal up and turn the pump on. As the pressure increases, ensure the centre lines on the top and former are aligned.



Shaping the panel side – end of cut. Note: the guard is removed for the photograph only



Box sides before shaping (top) and after shaping (bottom) – note over-length pins

THE BOX CARCASS

The carcass consists of shaped side pieces dovetailed to the front and back, and a cedar of Lebanon (*Cedrus libani*) bottom fits in a 4mm ($\frac{1}{8}$ in) groove. The lid pivots in 9mm ($\frac{3}{8}$ in) holes at the back of each side.

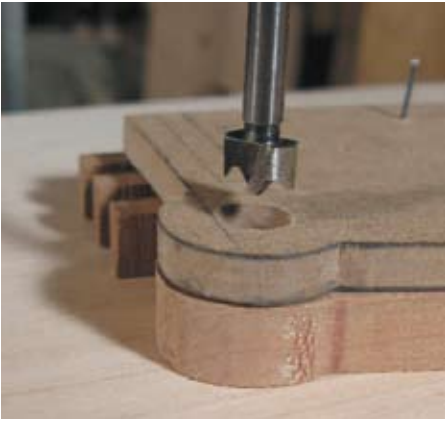

Drilling the side for the hinge spigot using the template

Prepare a template to aid the shaping of the sides. The radius of the top curve should be 5mm ($\frac{3}{16}$ in) greater than the external radius of the lid, similarly make the radius of the hinge boss 5mm greater than the radius of the hinge piece. The template is used to drill the pivot hole for the lid, so accurately drill a 9mm hole in the centre of the hinge boss.

Construction of the base is fairly straightforward. Prepare the 11mm ($\frac{7}{16}$ in) thick front, back and side pieces to length, leaving the side pieces slightly wider than required to allow for final shaping – they are not shaped at this point to aid marking out of the pins. Shoot the ends of all four pieces, and mark out and cut the dovetails on the front and back pieces. The back of the box is shaped to allow the radius round the lid hinge – the centre of the back piece, when fitted, should be in line with the centre of the lid hinge. Cut the pins and test the fit, then cut the back pins to length. The secret of good dovetails – if there is a secret – is careful marking out and exquisitely sharp tools.

Check that the bottom of the corners are all flush. The sides can now be shaped using a template and bearing



Set-up for routing the groove



Fielding the bottom panel on the router table. Guard is removed for photograph only

guided panel trim on the router table. Fix the template to the sides using veneer pins located, so that the holes are removed by the routing of the bottom groove. Before removing the template, drill 9mm pivot holes

“Some may say this is overkill and I could have got away with less supports or ply layers, however, experience has shown that scrimping at this stage can lead to unwanted undulating curves where the vacuum has distorted the former.”

8mm ($\frac{5}{16}$ in) deep. Use a bearing guided cutter to put a slight rounding on the edges of the top curve and boss. Use a sharp chisel to cut in where the curve of the boss meets the main curve of the sides. Cut the 4mm ($\frac{5}{32}$ in) groove for the bottom on the router table. Be sure to stop the cut to prevent the groove showing on the ends.

THE LID

The lid consists of the curved laminated panel grooved into a back hinge piece – the lid pivots on spigots at each end of the hinge piece. Turn the walnut hinge piece 19mm ($\frac{3}{4}$ in) in diameter – it should be 1mm ($\frac{3}{64}$ in) shorter than the distance between the dovetail shoulders of the back,



Box jig for holding the spine in order to rout the groove

with additional 9mm diameter spigots, 15mm ($\frac{9}{16}$ in) long at each end, which will be trimmed to 7.5mm at a later date. It is obvious that great accuracy is required as the spigots need to be precise, and any

variation in diameter along the length will be evident when the lid is assembled. I use a digital Vernier rather than my usual turning callipers which I sometimes find inaccurate.

JIG

A jig is required to aid the routing of the groove in the hinge piece – this consists of a box with precise slots at either end to receive the spigots. Locate the hinge piece in the jig and check that it is level with the top surface of the jig. Although it may be a tight fit in the jig, it is worth retaining the piece to prevent it vibrating loose while routing, so drive a screw in through the side of the slot to just nip the end of the spigot – this is why they were turned over length. >



Checking the lid for square in two dimensions



End of back piece showing the curved profile for the lid hinge

<GROOVES

The curved lid will be approximately 10mm ($\frac{3}{8}$ in) thick. You will probably need two cuts to rout a groove the required width. Use a piece of scrap to test the second cut until it is spot on. Cut the depth so that the bottom of the groove is in line with the spigot. I use a MicroFence on my router, which is very useful for this operation. After the first cut, I use a digital Vernier to measure the groove width and the lid thickness, then dial in the difference on the fence adjuster to obtain the correct groove width.

SIZING

Next, cut the lid panel to size. This can be tricky on a curved panel – firstly it won't sit neatly on the saw table or allow use of a scoring blade, and secondly it is important that it is cut in line with the axis of curvature. I was unsure of the best way to approach this and considered using a jig to hold the piece for a slitting cutter on the router table, but I found that a sharp fine tooth bandsaw gave a clean accurate cut with no breakout of the veneer.

Mark a line for the back edge parallel to the centre line, originally marked when the lid was laminated. Use a cradle to hold the piece so that the saw blade is at 90° to the tangent of the curve, cut to the marked line – if necessary, lightly plane to the line. Now cut to length using the sliding fence on the bandsaw. It is possible to check if the ends are cut square by placing the lid upright on a flat board and checking that it is standing square and true.

ASSEMBLY

Before beginning assembly, the front and back pieces must be shaped to fit the lid. Put a concave profile on the top edge of the back using a 10mm ($\frac{3}{8}$ in) radius ball head cutter on the router table. Cut a slope on the front piece to allow for the curvature of the lid – the angle can be obtained from the original drawing.

Dry assemble the box and lid, and check the action of the lid, making any adjustments if the hinge piece is rubbing. Mark the line of the front of the box on the lid – the curve on the front of the lid can now be marked and cut.

Before final assembly, apply a finish to the internal surfaces and the whole of the lid, ensuring that gluing surfaces are masked off.

The box can now be wet assembled. After removing the clamps, clean up the dovetail ends – you may have to use a chisel for this job on the back corners, as the hinge bosses impede the use of a plane.



Lid and spine glued-up

FINISH

I used Finney's Microporous Hardwax Oil to finish all the walnut and maple parts, with the cedar left unfinished. Apply the oil sparingly with a pad made from a rag wrapped around some wadding. The aim is to apply a number of thin coats rather than a couple of thick coats. The use of the pad gives a more even cover and facilitates working into

difficult corners. Cut back with 400grit paper between applications. Four or five coats should be adequate. Finally, after allowing 24 hours curing, rub down sparingly with bees wax and 0000 steel wool. Allow the wax to harden for about four hours then buff with a soft cloth. This should give a fine satin finish.

Next Month: We will look at the table to accompany the curved box. F&C

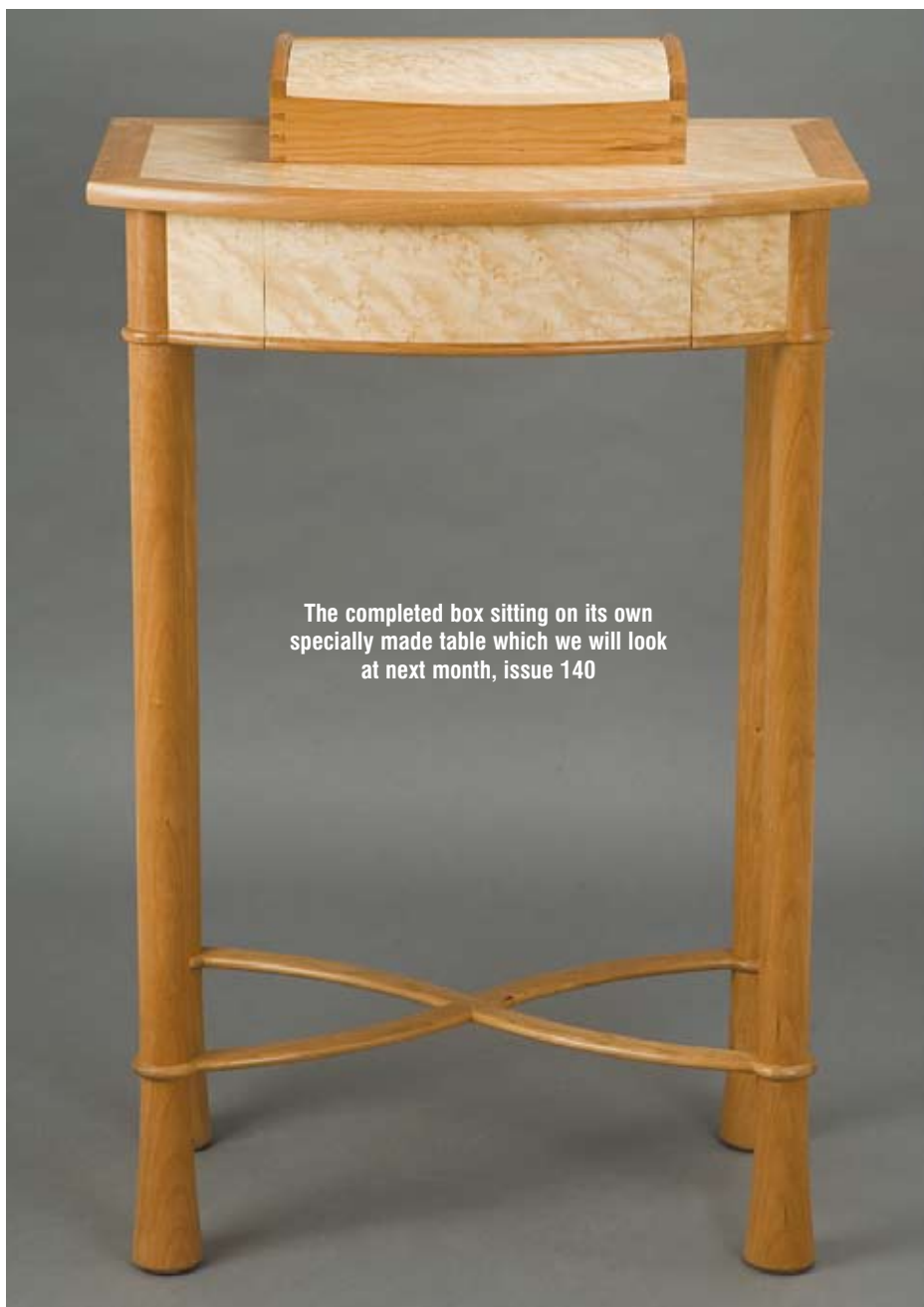

The completed box sitting on its own specially made table which we will look at next month, issue 140